

# Adjustable O2 simulator Manual



Adjustable o2 simulator module is intended for custom applications when ready to use o2 simulator is not available or there is a need to tweak simulator parameters from time to time. Adjustable module allows changing low and high voltage levels as well as signal frequency.

## Features:

- Designed for 1 volt oxygen sensors only.
- Adjustable low and high values from 0 to 1 volt.
- Adjustable signal frequency from 90 to 5 cycles per minute.
- Configuration is done via LCD display.

## Installation procedure

Warning: *Removing or defeating vehicle emission system may be prohibited in your state or country. Please check you local state laws.*

### **1. Locate secondary o2 sensor (sensors).**

### **2. Locate oxygen sensor signal wire (Standard 1v sensors).**

The best way to find oxygen sensor signal wire is to look it up in your Haynes, Clymer or Chilton manual for your car. For a small fee (10-15\$) you can get diagram e-mailed to you from <http://www.ahdol.com>.

Another source is AutoZone.com.

Go to the following URL: [www.autozone.com/shopping/vehicleSelect1.htm](http://www.autozone.com/shopping/vehicleSelect1.htm)

Then:

1. Locate your car, year, make and model.
2. Select "Repair Info" on the left side of the screen.
3. Select, "Vehicle Repair Guides" -> Chassis Electrical -> Wiring Diagrams.

Use wiring diagram to identify color of the o2 sensor wires. If you still can not get wiring diagram, locate o2sensor. In most cases the oxygen sensor has four wires:

- Heater 12 Volts +
- Heater ground
- Oxygen sensor signal +
- Oxygen sensor signal ground

Usually on a 4-wire sensor two white wires are for the heating element, a gray wire is ground and a black wire is signal or two black for sensor heater, blue is signal and white is ground.

If you have 2 or 3 wires, then your oxygen sensor has a common ground or no heater wires etc. The simplest setup is a single wire, which is the signal wire. The following procedure will help you to identify the wires:

Disconnect the o2 sensor plug, use multi-meter and find two wires (measure sensor wires) with low resistance about 2-30 Ohm. That is o2 sensor heater circuit. The other two are sensor signal and sensor ground wires. You need to find the sensor signal. Strip insulation from the wires so the voltage can be measured. Now start the car and use multi-meter to probe the voltage between those two wires. You need to see Positive reading (between 0.1 and 0.8v) on the multi-meter, the Red probe will be your signal wire and Black is sensor ground. If you see negative voltage, reverse the probes.

### 3. Locate 12 Volt power and Ground.

Find ignition switching power wire. O2 sensor heater wire can not be used because in some cases ECU will cut the power to the o2 sensor during the trip. LCD module draws about 0.1A so you can connect it to any power source. Ground can be the vehicle body (chassis ground), engine block or ground from another device. Do not use oxygen sensor ground. Test the resistance between ground wire and battery negative terminal, if it is  $< 2$  ohm you can use it.

### 4. Placing adjustable o2 simulator module.

Place LCD module so it is accessible for adjustment.

### 5. Disconnect negative battery terminal.

### 6. Connect simulator module to the Ground and 12V source.

### 7. Connect simulator.

Connect simulator output (IN\_1/OUT\_1 to the o2 sensor wires as shown in the picture below). If you have second oxygen sensor use IN\_2/OUT\_2. If the second oxygen sensor is not present isolate IN\_2/OUT\_2 wires with electrical tape. Do not short the wires together.

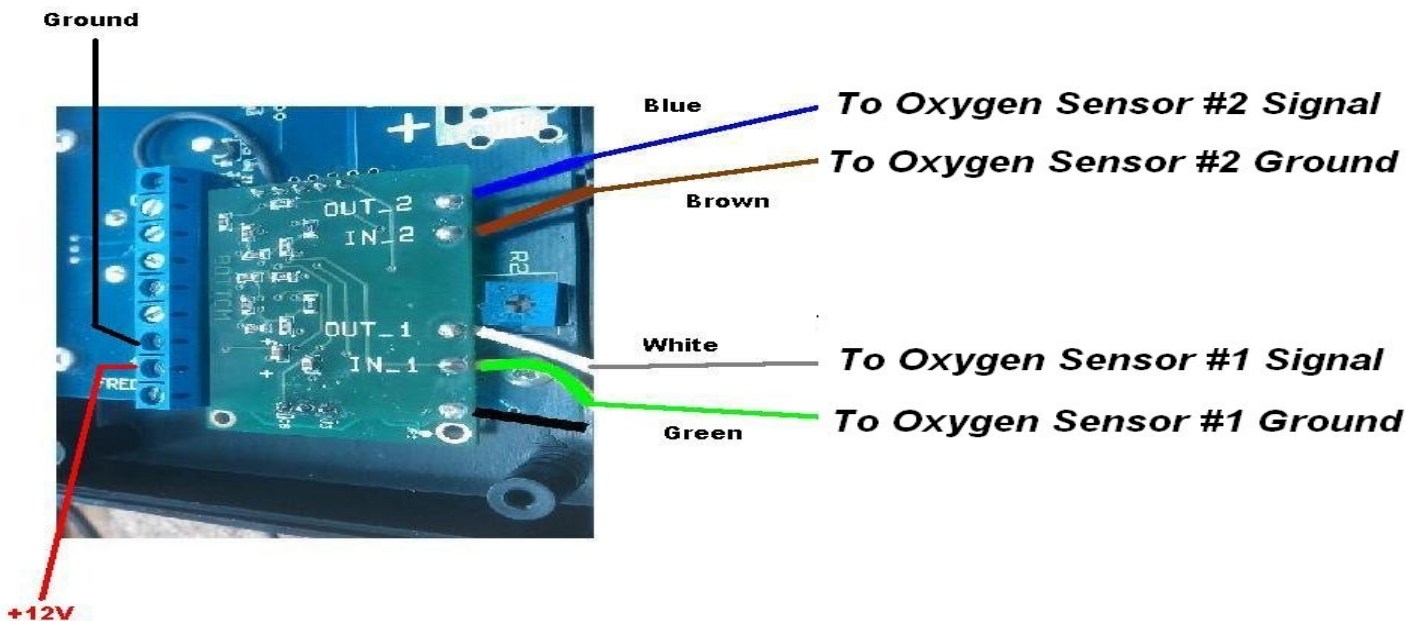

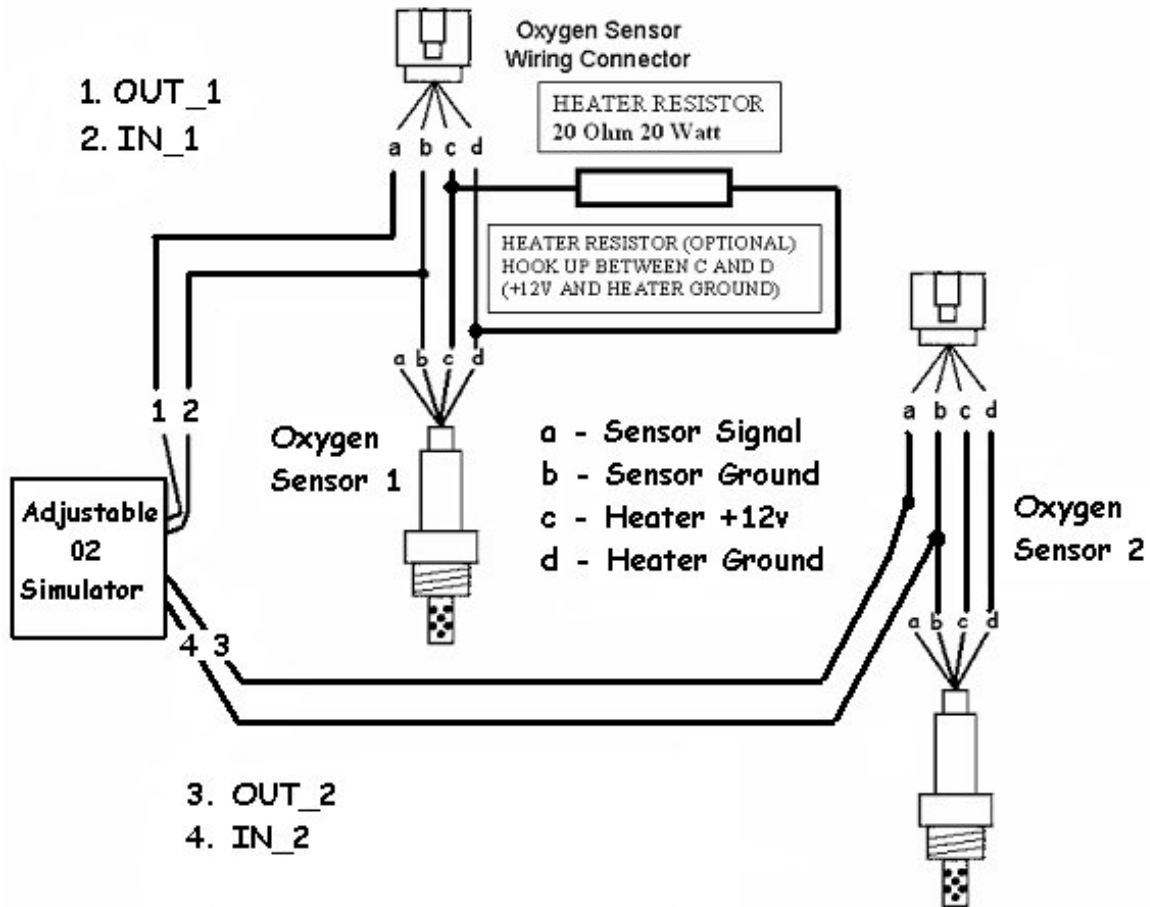

**8. Reconnect negative battery terminal.**

**9. Configuration.**

Adjustable simulator module menus:

1. Set Low Level Voltage Output
2. Set High Level Voltage Output
3. Set Frequency Cycles per Minute

Start with about 300mV for Low, 650mV for high voltage and 12 cycles per min. If you get High voltage error code decrease high voltage level. Keep adjusting frequency if you get 'catalytic efficiency' codes. There is no specific procedure how to get to the perfect settings. It is done through trial and error approach.